

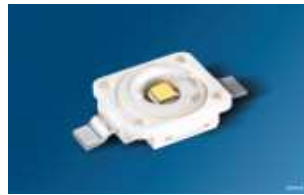

16 mm : LLC01N LLC01M LLC01W LLC01X LLC01S LLC01E  
32 mm : LLC05N LLC05M LLC05W  
35 mm : LLC17N

**OSRAM** GOLDEN DRAGON datasheet  
Opto Semiconductors



*LednLight, a high performance LED collimator series,  
for all your high power LEDs lighting applications*



**Benefits of the Lednlight  
product range:**

- Innovative and unique design, which allows you to use most existing LEDs references
- Homogeneous light distribution, resulting from software optimization and quality polymer
- Available with mechanical holder for ease of use and production
- Ready to use and easy integration into a cluster part

**Characteristics of collimator LLC01E:**

- Compatible with automotive standards (ECE and SAE)
- Compatible with traffic light standards (class M)

**Characteristics of collimator LLC01X:**













- Broad light distribution, suitable for outdoor lighting

**Characteristics of collimator LLC05N :**

- Reduced divergence and high brightness light beam for all for long range lighting applications
- Compliant with surgical lighting applications

# Osram GOLDEN DRAGON datasheet

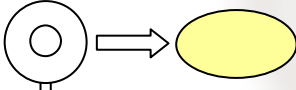





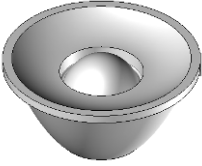

## Optical Characteristics, overview table

Collimator	LED	Half angle at 50%		Half angle at 10%		Efficiency in CD/LM	Holder & Options
 <b>LLC01N</b>	Golden Dragon AlInGaP (red)	6.3		14.0		10.4	MONO MONO + ADHESIVE TRI QUADRI
	Golden Dragon Plus warm white	6.1		12.7		11.7	
							
 <b>LLC01M</b>	Golden Dragon AlInGaP (red)	9.9		19.2		5.5	MONO MONO+ ADHESIVE TRI QUADRI
	Golden Dragon InGaN (blue/green)	9.0		19.2		5.6	
	Golden Dragon Plus warm white	9.6		18.6		5.9	
							
 <b>LLC01W</b>	Golden Dragon AlInGaP (red)	16.1		25.3		2.8	MONO MONO+ ADHESIVE TRI QUADRI
	Golden Dragon InGaN (blue/green)	14.4		25		2.9	
	Golden Dragon Plus warm white	16.6		25.5		2.7	
							
 <b>LLC01X</b>	Golden Dragon AlInGaP (red)	16.5		37.7		1.5	MONO MONO+ ADHESIVE TRI QUADRI
	Golden Dragon InGaN (blue/green)	14.5		35		1.7	
	Golden Dragon Plus warm white	14.6		33.8		1.8	
							
 <b>LLC01S</b>	Golden Dragon AlInGaP (red)	27.7		42.6		0.9	MONO MONO+ ADHESIVE TRI QUADRI
	Golden Dragon InGaN (blue/green)	26.1		42.1		1.0	
	Golden Dragon Plus warm white	26.8		41.1		1.0	
							
 <b>LLC01E</b>	Golden Dragon AlInGaP (red)	8.8v	15.7h	18.5v	26.3h	3.6	MONO MONO+ ADHESIVE TRI QUADRI
	Golden Dragon InGaN (blue/green)	9.7v	15.3h	20.8v	27.1h	3.0	
	Golden Dragon Plus warm white	8.5v	15.3h	17.9v	26.2h	3.8	
							

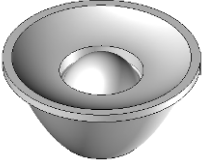
# Osram GOLDEN DRAGON datasheet

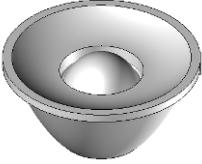
## Optical Characteristics, overview table

32 & 35mm LednLight range

Collimator	LED	Half angle at 50%	Half angle at 10%	Efficiency in CD/LM	Holder & Options
 <b>LLC05N</b>	Golden Dragon cool white	2.5	4.6	76.1	MONO MONO+ ADHESIVE
					
 <b>LLC05M</b>	Golden Dragon cool white	8.0	18.1	6.2	MONO MONO+ ADHESIVE
					
 <b>LLC05W</b>	Golden Dragon cool white	9.5	21.6	4.6	MONO MONO+ ADHESIVE
					
 <b>LLC17N</b>	Golden Dragon cool white	3.1	7.5	36.4	
					



## Optical characteristics and intensity distribution Collimator LLC01N - Osram series

Measurements done with  
Ledgon 100 photogoniometer

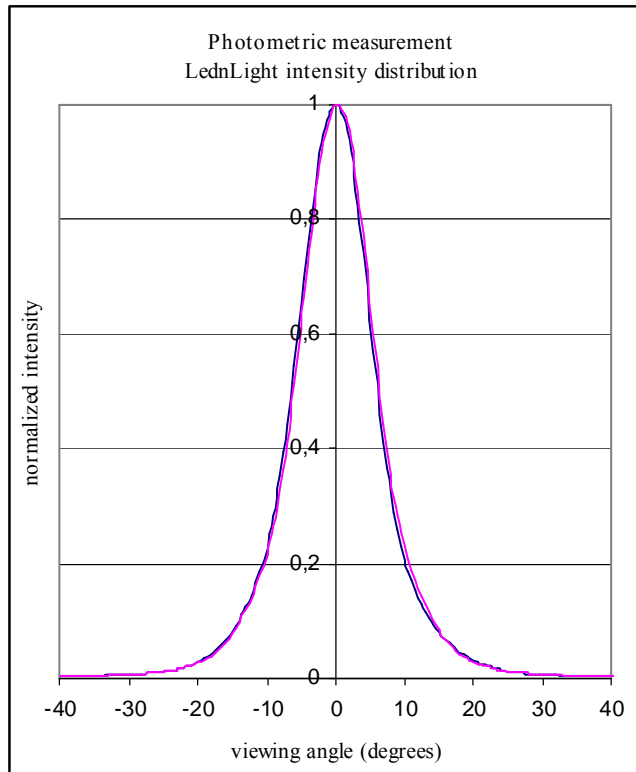

- Golden Dragon AlInGaP (red)  
@ 350 mA (reference  
LAW57B)
- Narrow circular beam
- Efficiency in candelas per  
lumen : 10,4 cd/lm
- Half-angle at 50% from  
maximum 6.3°
- Half-angle at 10% from  
maximum 14.0°
- Available with dedicated  
holder (LLH01DRA00  
LLH03DRA01 & LLH04DRA01 )

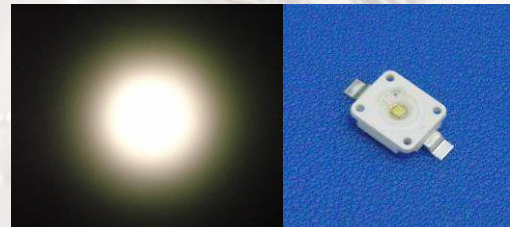
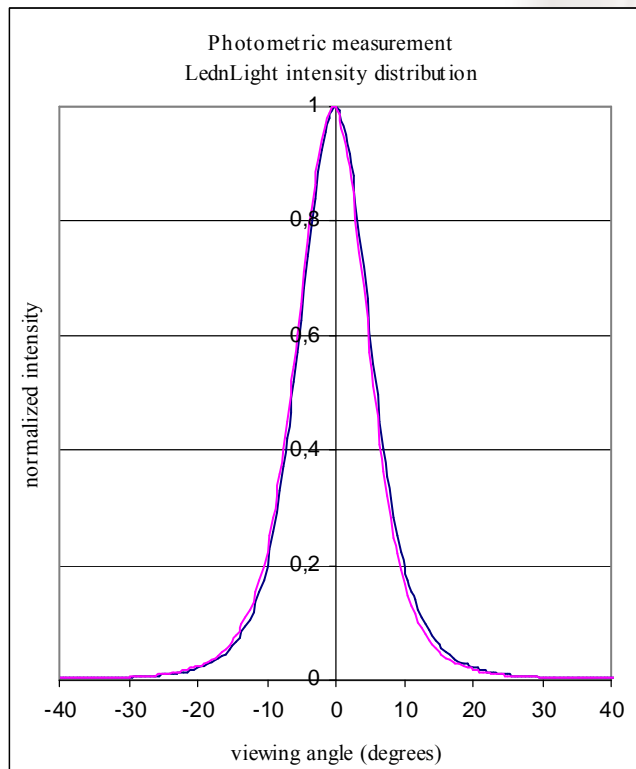

- Golden Dragon Plus warm  
white @ 350 mA (ref.  
LCW\_W5AM)
- Narrow circular beam
- Efficiency in candelas per  
lumen : 11,7 cd/lm
- Half-angle at 50% from  
maximum 6,1°
- Half-angle at 10% from  
maximum 12,7°
- Available with dedicated  
holder (LLH01DRA00  
LLH03DRA01 & LLH04DRA01 )



## Optical characteristics and intensity distribution Collimator LLC01M - Osram series

Measurements done with  
Ledgon 100 photogoniometer

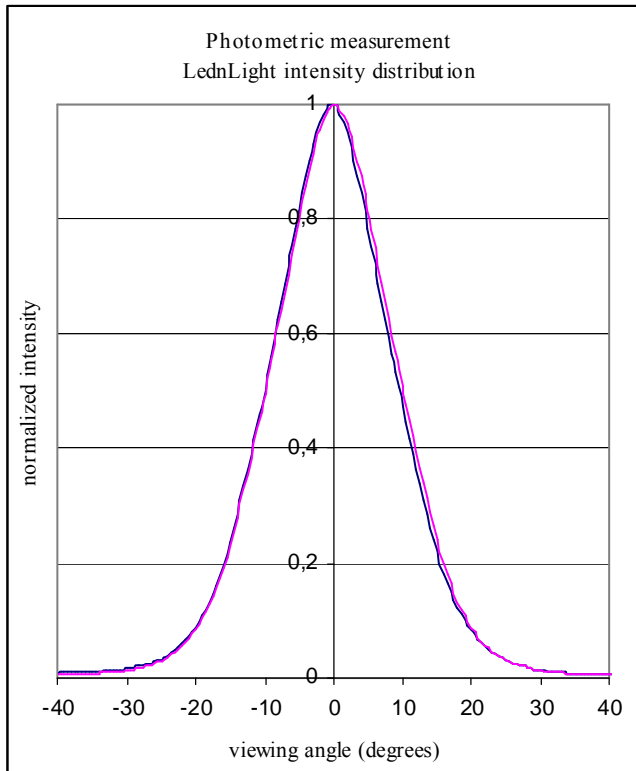

- Golden Dragon AlInGaP (red) @ 350 mA (reference LAW57B)
- Medium circular beam
- Efficiency in candelas per lumen : 5,5 cd/lm
- Half-angle at 50% from maximum 9.9°
- Half-angle at 10% from maximum 19.2°
- Available with dedicated holder (LLH01DRA00 LLH03DRA01 & LLH04DRA01)

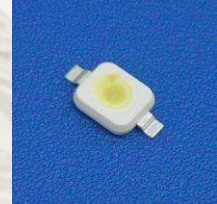
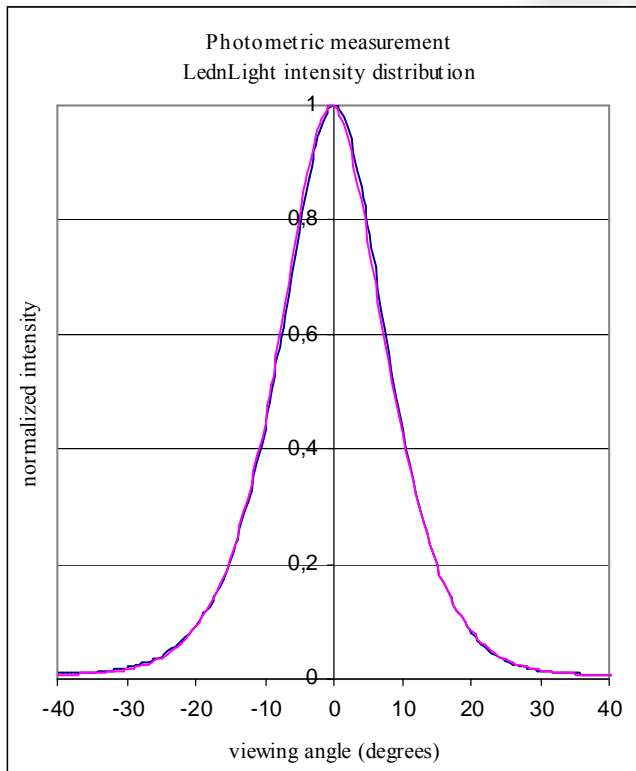

- Golden Dragon InGaN (blue/green) @ 350 mA (reference LVW5SG)
- Medium circular beam
- Efficiency in candelas per lumen : 5,6 cd/lm
- Half-angle at 50% from maximum 9,0°
- Half-angle at 10% from maximum 19,2°
- Available with dedicated holder (LLH01DRA00 LLH03DRA01 & LLH04DRA01)



## Optical characteristics and intensity distribution Collimator LLC01M - Osram series

Measurements done with  
Ledgon 100 photogoniometer

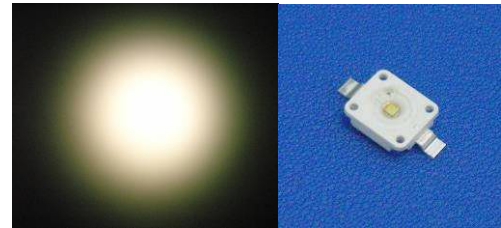
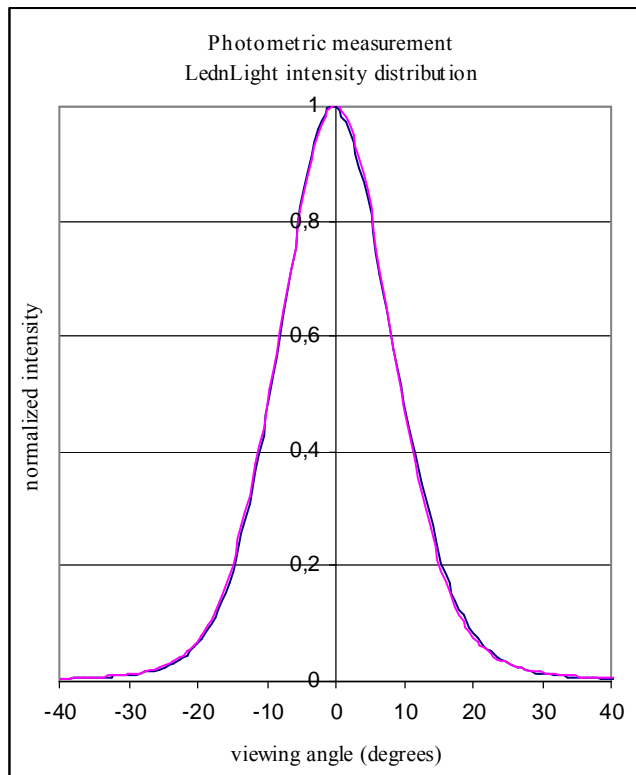

- Golden Dragon Plus warm white @ 350 mA (ref. LCW\_W5AM)
- Medium circular beam
- Efficiency in candelas per lumen : 5,9 cd/lm
- Half-angle at 50% from maximum 9,6°
- Half-angle at 10% from maximum 18,6°
- Available with dedicated holder (LLH01DRA00 LLH03DRA01 & LLH04DRA01)



## Optical characteristics and intensity distribution Collimator LLC01W- Osram series

Measurements done with  
Ledgon 100 photogoniometer

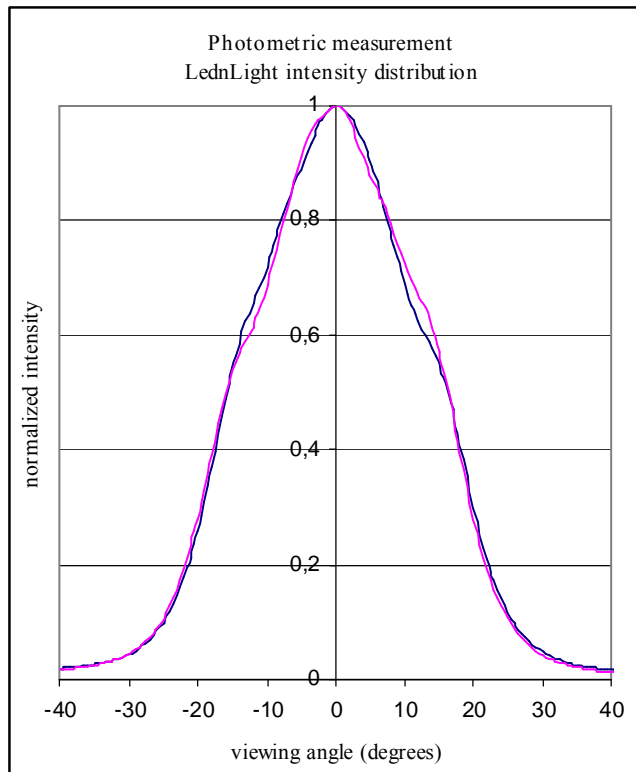

- Golden Dragon AlInGaP (red) @ 350 mA (reference LAW57B)
- Large circular beam
- Efficiency in candelas per lumen : 2,8 cd/lm
- Half-angle at 50% from maximum 16,1°
- Half-angle at 10% from maximum 25,3°
- Available with dedicated holder ((LLH01DRA00 LLH03DRA01 & LLH04DRA01 )

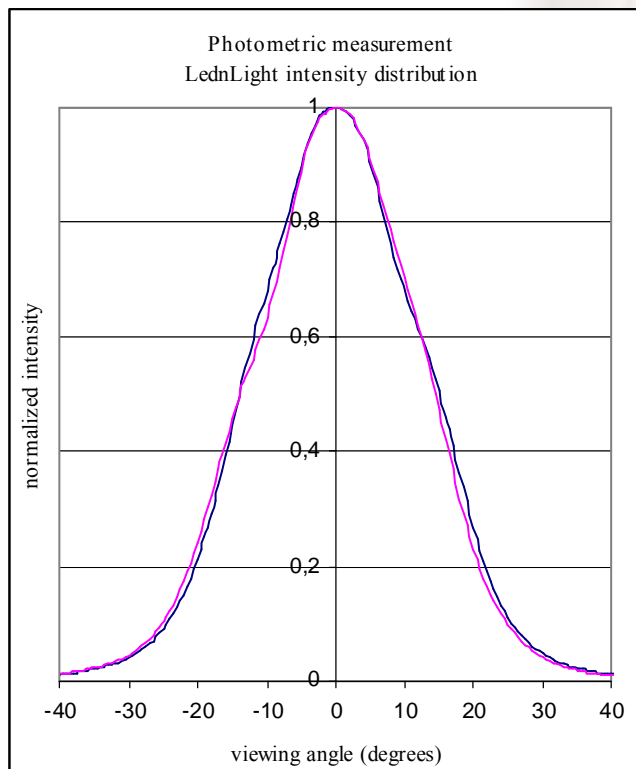

- Golden Dragon InGaN (blue/green) @ 350 mA (reference LVW5SG)
- Large circular beam
- Efficiency in candelas per lumen : 2,9 cd/lm
- Half-angle at 50% from maximum 14,4°
- Half-angle at 10% from maximum 25,0°
- Available with dedicated holder (LLH01DRA00 LLH03DRA01 & LLH04DRA01 )



## Optical characteristics and intensity distribution Collimator LLC01W - Osram series

Measurements done with  
Ledgon 100 photogoniometer

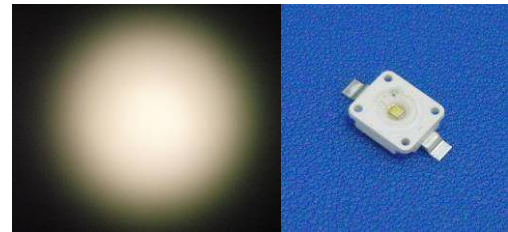
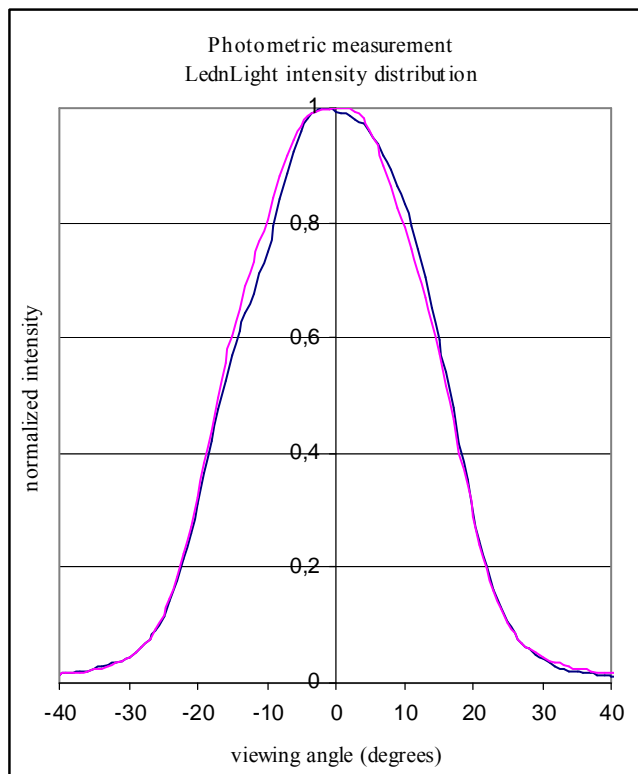

- Golden Dragon Plus warm white @ 350 mA (ref. LCW\_W5AM)
- Large circular beam
- Efficiency in candelas per lumen : 2,7 cd/lm
- Half-angle at 50% from maximum 16,6°
- Half-angle at 10% from maximum 25,5°
- Available with dedicated holder (LLH01DRA00 LLH03DRA01 & LLH04DRA01)

**Optical characteristics and intensity distribution  
Collimator LLC01X- Osram series**

Measurements done with  
Ledgon 100 photogoniometer

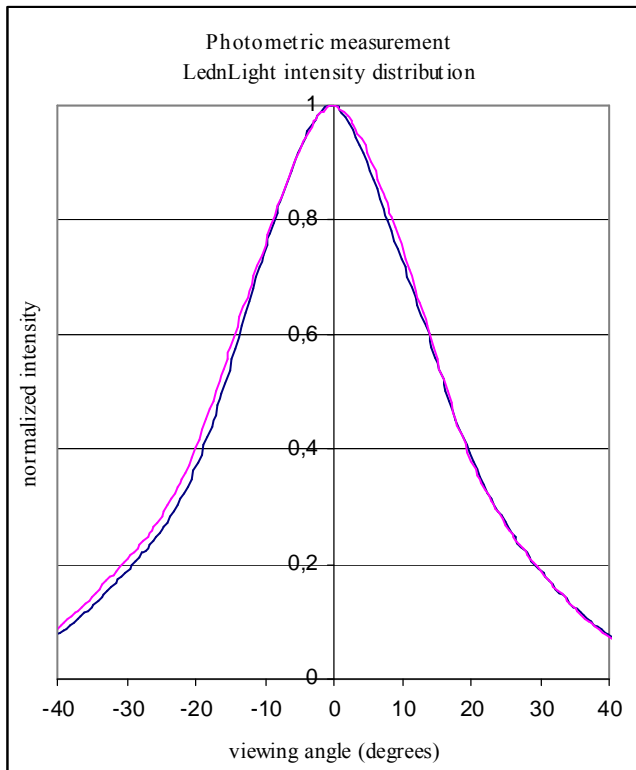
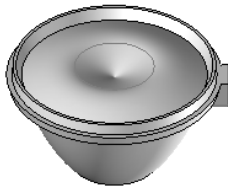

- Golden Dragon AlInGaP (red) @ 350 mA (reference LAW57B)
- Ultra wide beam
- Efficiency in candelas per lumen : 1.5 cd/lm
- Half-angle at 50% from maximum 16.5°
- Half-angle at 10% from maximum 37.7°
- Available with dedicated holder ((LLH01DRA00 LLH03DRA01 & LLH04DRA01 )

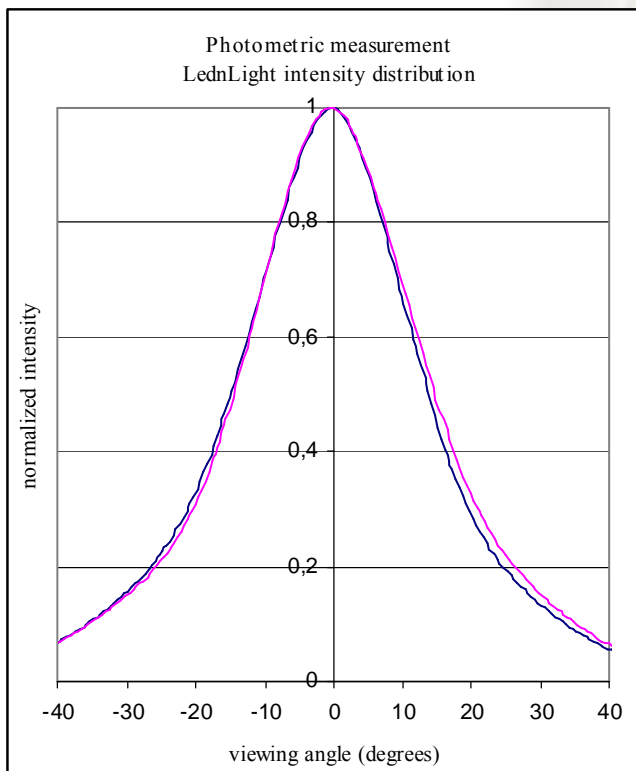

- Golden Dragon InGaN (blue/green) @ 350 mA (reference LVW5SG)
- Ultra wide beam
- Efficiency in candelas per lumen : 1.7 cd/lm
- Half-angle at 50% from maximum 14.5°
- Half-angle at 10% from maximum 35.0°
- Available with dedicated holder (LLH01DRA00 LLH03DRA01 & LLH04DRA01 )



## Optical characteristics and intensity distribution Collimator LLC01X- Osram series

Measurements done with  
Ledgon 100 photogoniometer

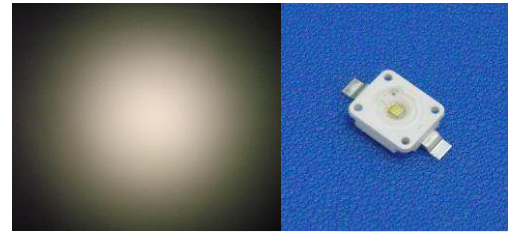
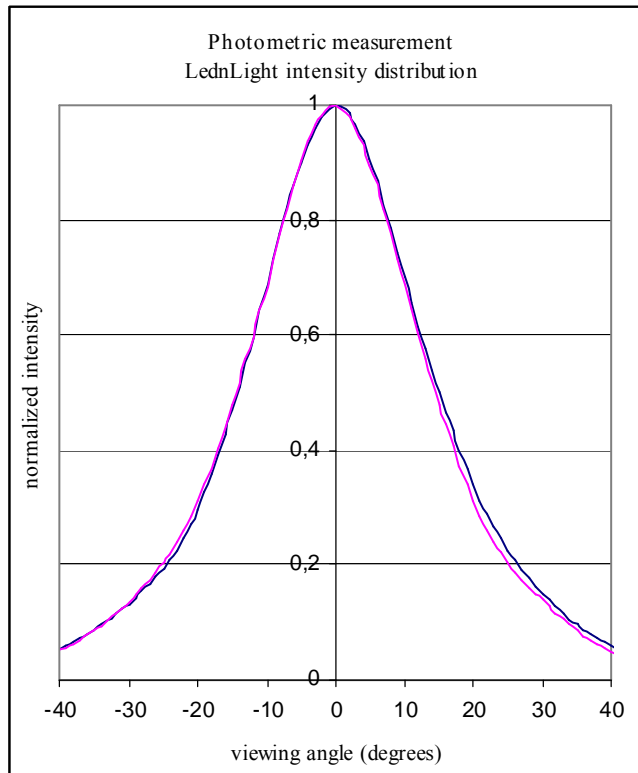

- Golden Dragon Plus warm white @ 350 mA (ref. LCW\_W5AM)
- Ultra wide beam
- Efficiency in candelas per lumen : 1.8 cd/lm
- Half-angle at 50% from maximum 14.6°
- Half-angle at 10% from maximum 33.8°
- Available with dedicated holder (LLH01DRA00 LLH03DRA01 & LLH04DRA01 )



## Optical characteristics and intensity distribution Collimator LLC01S- Osram series

Measurements done with  
Ledgon 100 photogoniometer

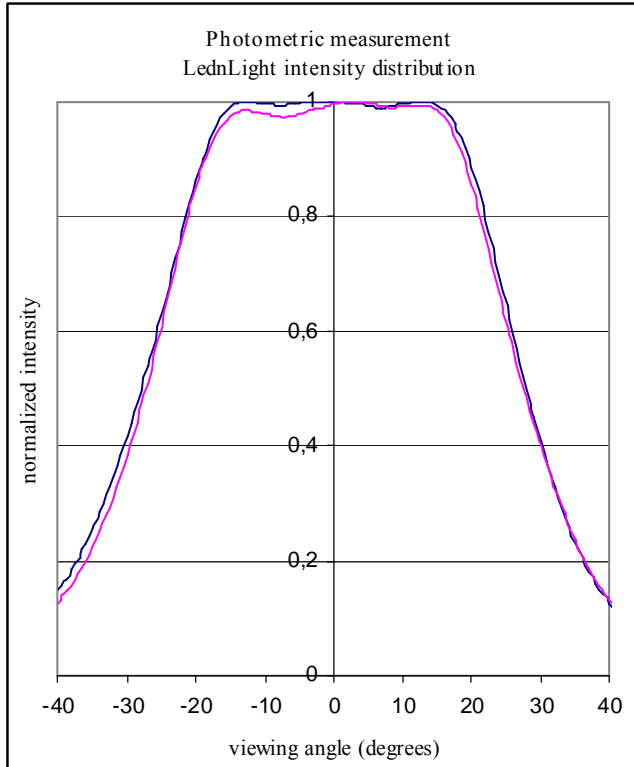

- Golden Dragon AlInGaP (red) @ 350 mA (reference LAW57B)
- Ultra wide beam
- Efficiency in candelas per lumen : 0.9 cd/lm
- Half-angle at 50% from maximum 27.7°
- Half-angle at 10% from maximum 42.6°
- Available with dedicated holder (LLH01DRA00, LLH03DRA01 & LLH04DRA01)

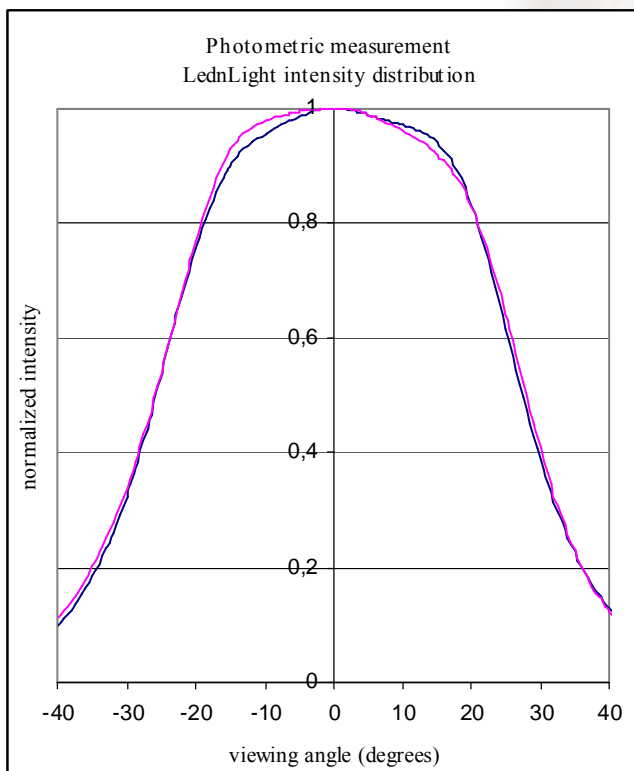

- Golden Dragon InGaN (blue/green) @ 350 mA (reference LVW5SG)
- Ultra wide beam
- Efficiency in candelas per lumen : 1.0 cd/lm
- Half-angle at 50% from maximum 26.1°
- Half-angle at 10% from maximum 42.1°
- Available with dedicated holder (LLH01DRA00 LLH03DRA01 & LLH04DRA01)

**Optical characteristics and intensity distribution  
Collimator LLC01S- Osram series**

Measurements done with  
Ledgon 100 photogoniometer

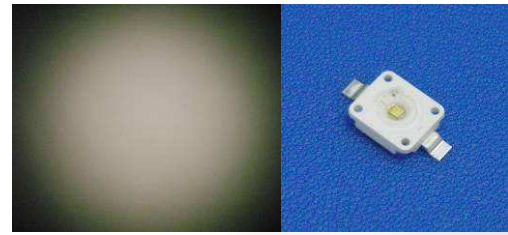
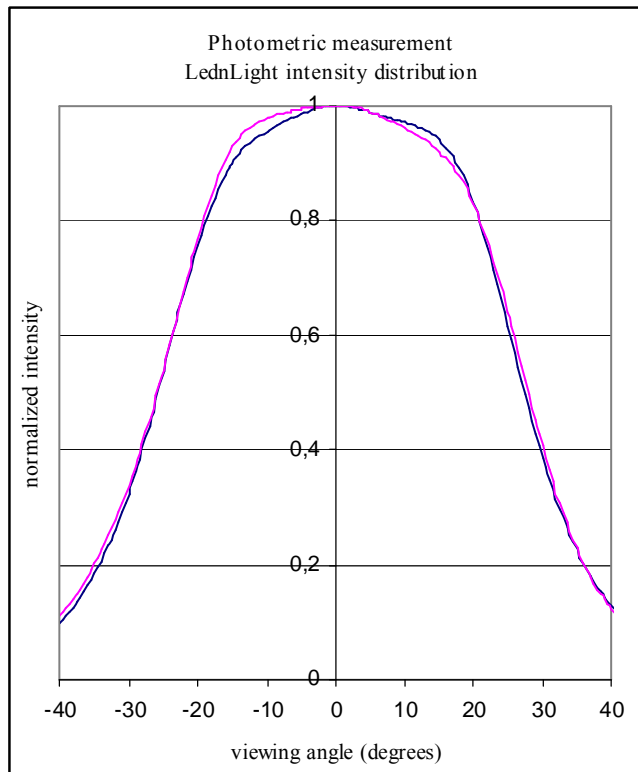

- Golden Dragon Plus warm white @ 350 mA (ref. LCW\_W5AM)
- Ultra wide beam
- Efficiency in candelas per lumen : 1.0 cd/lm
- Half-angle at 50% from maximum 26.8°
- Half-angle at 10% from maximum 41.1°
- Available with dedicated holder (LLH01DRA00 LLH03DRA01 & LLH04DRA01 )

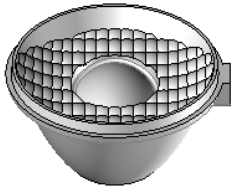

## Optical characteristics and intensity distribution Collimator LLC01E- Osram series

Measurements done with  
Ledgon 100 photogoniometer

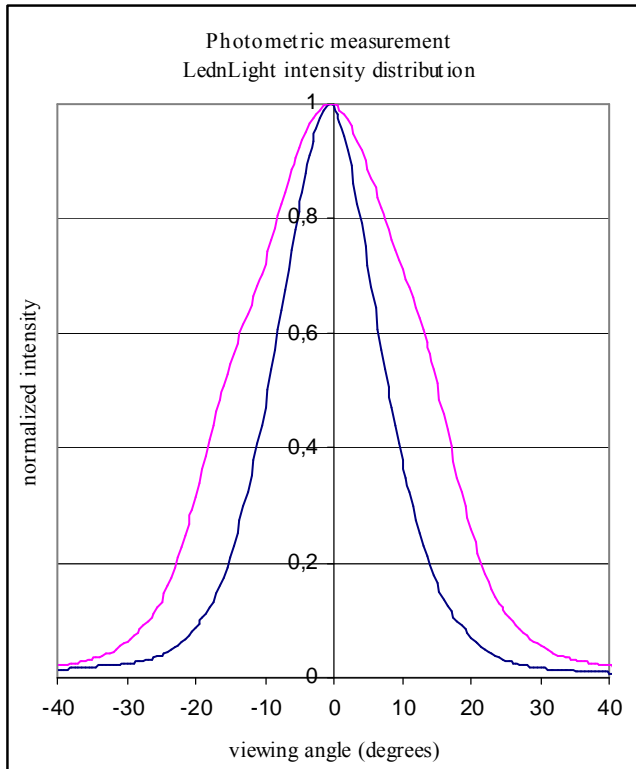

- Golden Dragon AlInGaP (red) @ 350 mA (reference LAW57B)
- Elliptical beam
- Efficiency in candelas per lumen : 3.6 cd/lm
- Half-angle at 50% from maximum 8.8°x15.7°
- Half-angle at 10% from maximum 18.5°x26.3°
- Available with dedicated holders (LLH01DRA00 LLH03DRA01 & LLH04DRA01 )
- Designed to meet automotive and traffic light standards

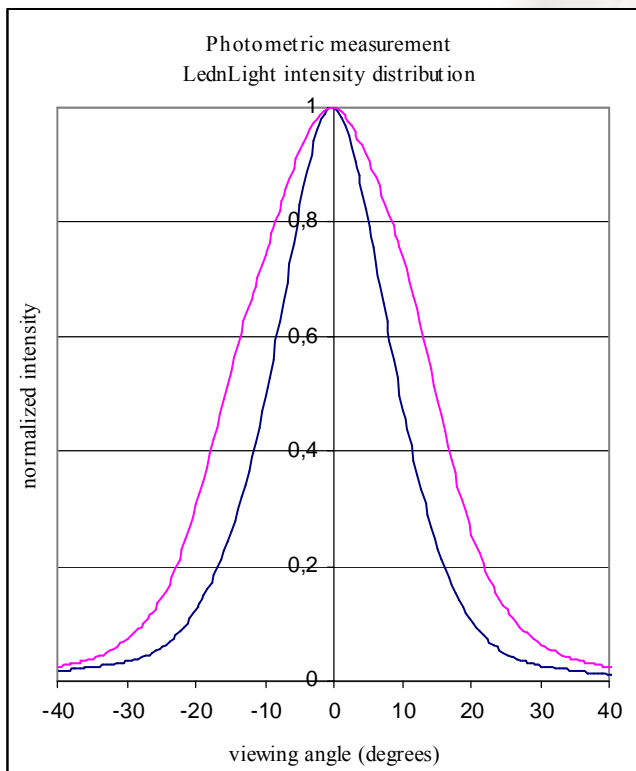

- Golden Dragon InGaN (blue/green) @ 350 mA (reference LVW5SG)
- Elliptical beam
- Efficiency in candelas per lumen : 3.0 cd/lm
- Half-angle at 50% from maximum 9.7°x15.3°
- Half-angle at 10% from maximum 20.8°x27.1°
- Available with dedicated holders (LLH01DRA00 LLH03DRA01 & LLH04DRA01 )
- Designed to meet automotive and traffic light standards



## Optical characteristics and intensity distribution Collimator LLC01E- Osram series

Measurements done with  
Ledgon 100 photogoniometer

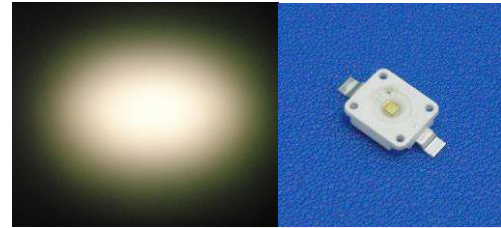
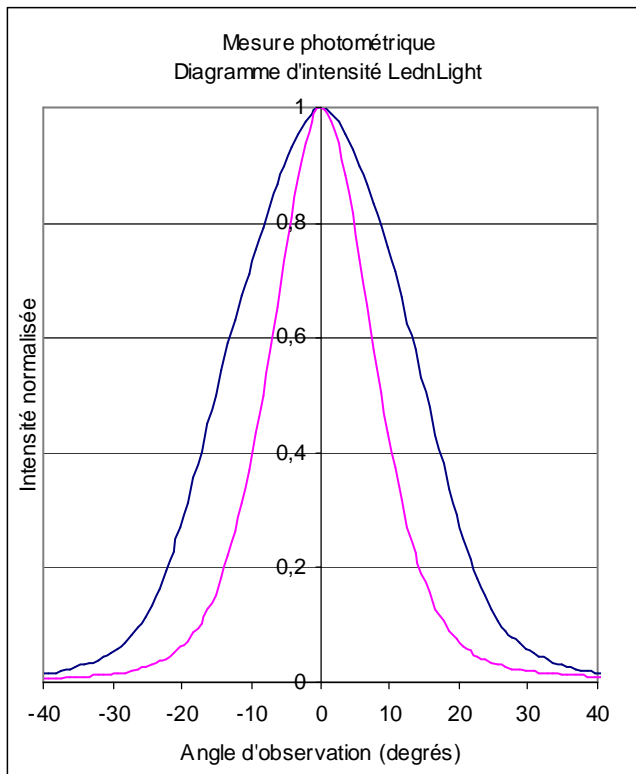

- Golden Dragon Plus warm white @ 350 mA (ref. LCW\_W5AM)
- Elliptical beam
- Efficiency in candelas per lumen : 3.8 cd/lm
- Half-angle at 50% from maximum 8.5°x15.3°
- Half-angle at 10% from maximum 17.9°x26.2°
- Available with dedicated holders (LLH01DRA00 LLH03DRA01 & LLH04DRA01 )
- Designed to meet automotive and traffic light standards

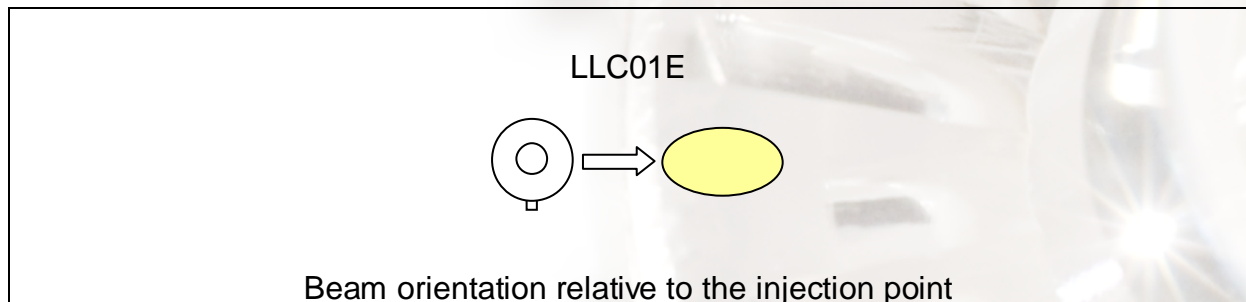

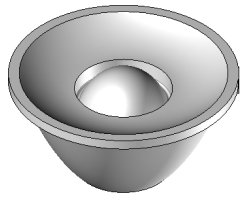

### Optical characteristics and intensity distribution Collimator LLC05N - Osram series

Measurements done with  
Ledgon 100 photogoniometer

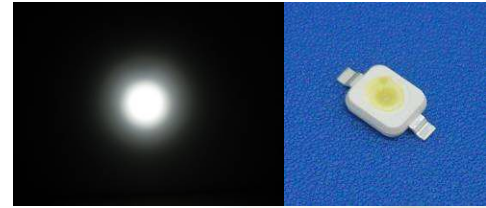
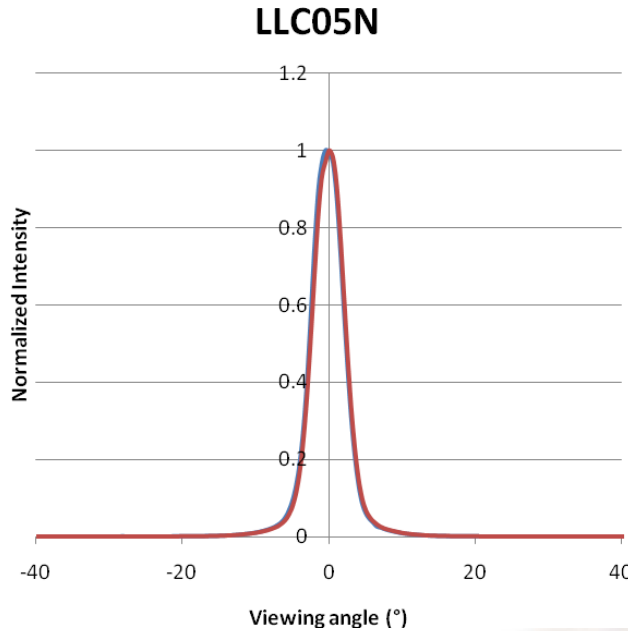

- Golden Dragon AlInGaP (red) @ 350 mA (reference LAW57B)
- Super narrow circular beam
- Efficiency in candelas per lumen : 76.1cd/lm
- Half-angle at 50% from maximum 2.5°
- Half-angle at 10% from maximum 4.6°
- Available with dedicated holder (LLH02DRA00)

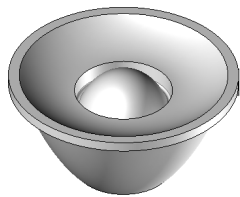

### Optical characteristics and intensity distribution Collimator LLC05M - Osram series

Measurements done with  
Ledgon 100 photogoniometer

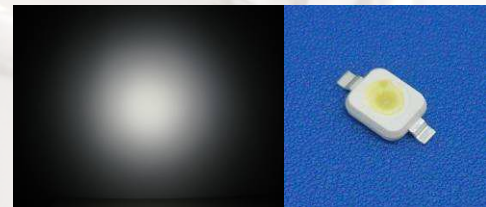
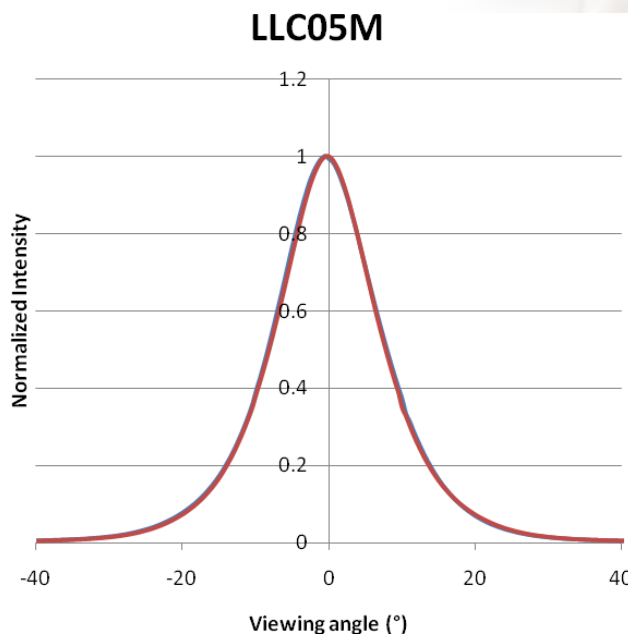

- Golden Dragon AlInGaP (red) @ 350 mA (reference LAW57B)
- medium circular beam
- Efficiency in candelas per lumen : 6.2 cd/lm
- Half-angle at 50% from maximum 8.0°
- Half-angle at 10% from maximum 18.1°
- Available with dedicated holder (LLH02DRA00)

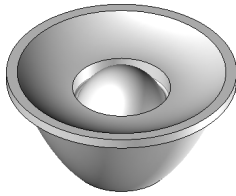

### Optical characteristics and intensity distribution Collimator LLC05W - Osram series

Measurements done with  
Ledgon 100 photogoniometer

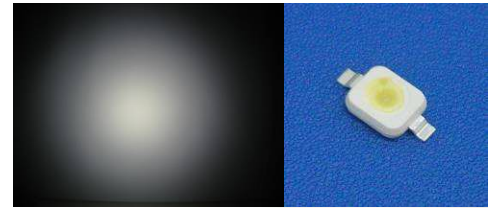
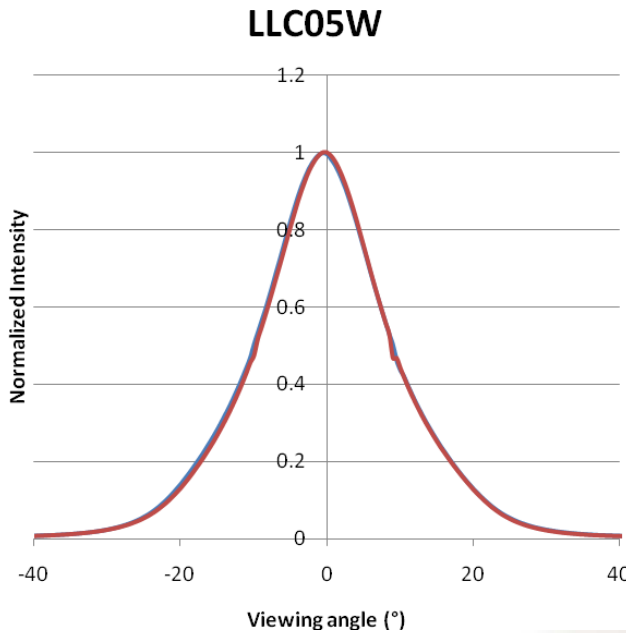

- Golden Dragon AlInGaP (red) @ 350 mA (reference LAW57B)
- Wide circular beam
- Efficiency in candelas per lumen : 4.6cd/lm
- Half-angle at 50% from maximum 9.5°
- Half-angle at 10% from maximum 21.6°
- Available with dedicated holder (LLH02DRA00)



### Optical characteristics and intensity distribution Collimator LLC17N - Osram series

Measurements done with  
Ledgon 100 photogoniometer

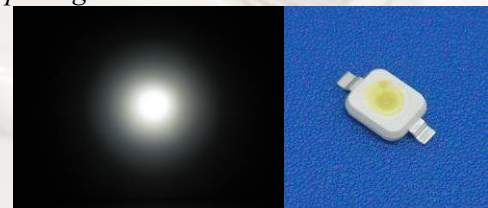
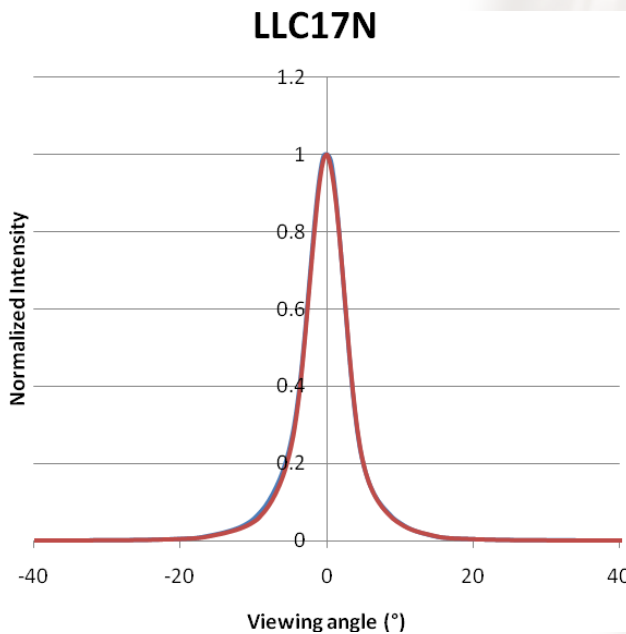

- Golden Dragon AlInGaP (red) @ 350 mA (reference LAW57B)
- Super narrow circular beam
- Efficiency in candelas per lumen : 36.4 cd/lm
- Half-angle at 50% from maximum 3.1°
- Half-angle at 10% from maximum 7.5°
- Available with dedicated holder (LLH02DRA00)

**Mechanical characteristics LLC01N, LLC01M, LLC01W, LLC01E, LLC01X and LLC01S**

*Without holder, all dimensions are in millimeters  
General tolerance +/-0.1 mm (standard NF T 58 -000 cat. 4, reduced class)*

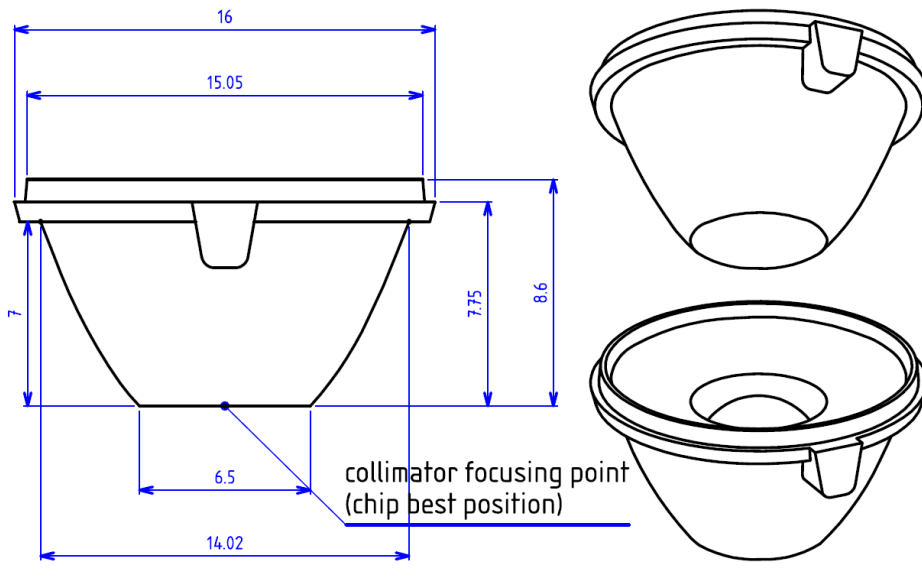

**Mechanical characteristics LLC01N, LLC01M, LLC01W, LLC01E, LLC01X and LLC01S**

*With holder, all dimensions are in millimeters  
General tolerance +/-0.1 mm (standard NF T 58 -000 cat. 4, reduced class)*

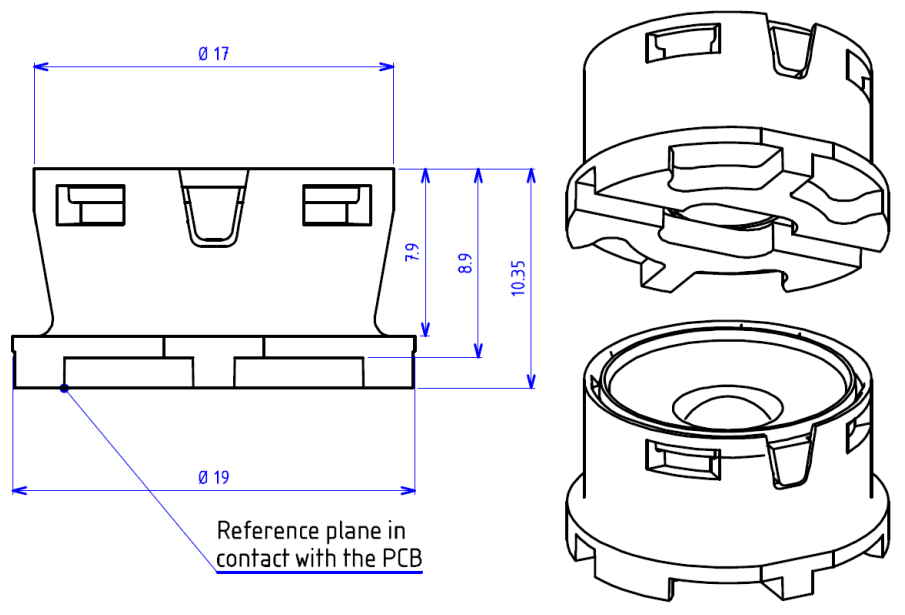

*Holder is the same for all Golden Dragon LED references. Mounting is done with a tight adjustment on the LED.*

*Note: available with our adhesive (acrylate or epoxy glu can also be used see your supplier).*

**Mechanical characteristics holder TRI LLH03DRA**

All dimensions are in millimeters  
General tolerance +/-0.15 mm (standard NF T 58-000 cat. 4, reduced class)

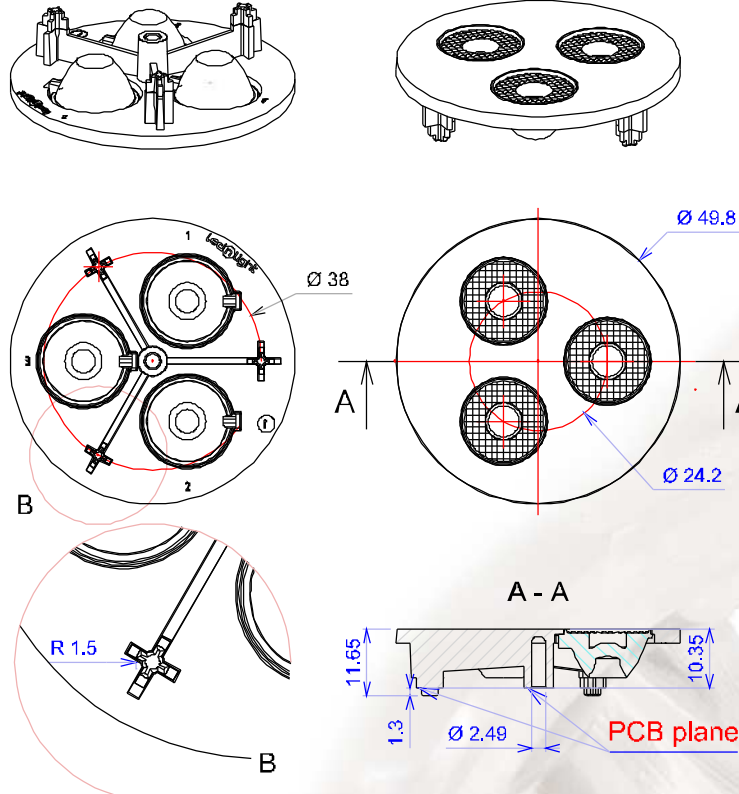

**Mechanical characteristics holder QUADRI LLH04DRA**

All dimensions are in millimeters  
General tolerance +/-0.15 mm (standard NF T 58-000 cat. 4, reduced class)

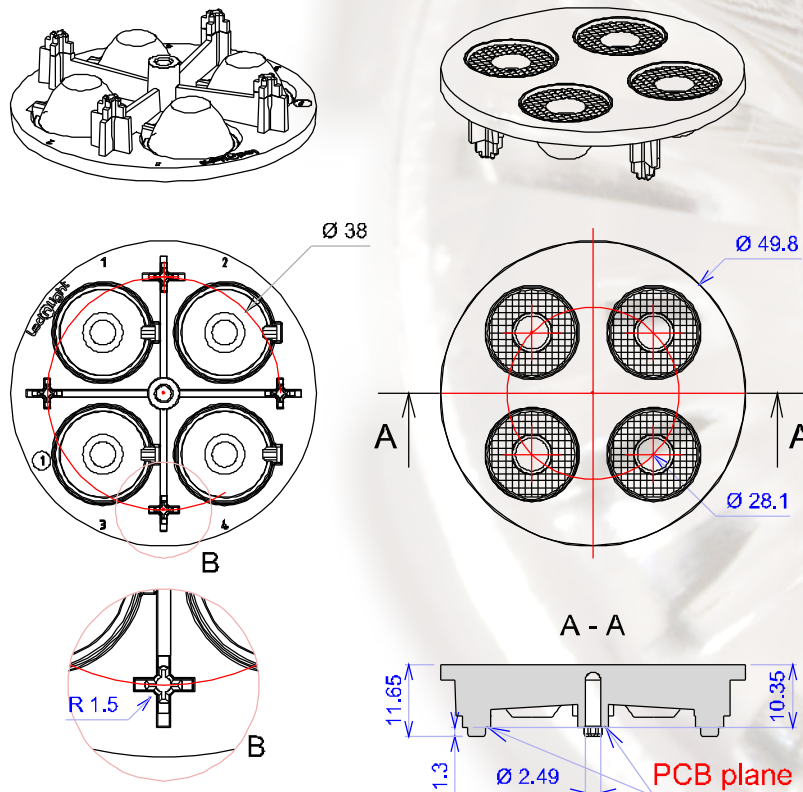

**Mechanical characteristics LLC05N**  
**Without holder, dimension is in millimeters**  
**General tolerance +/-0.15 mm (standard NF T 58 -000 cat. 4, reduced class)**

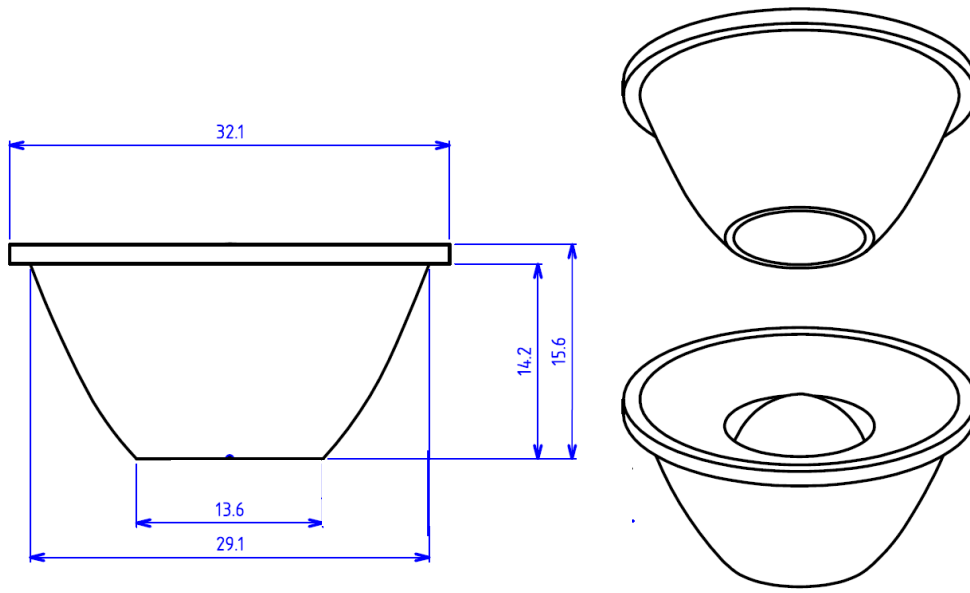

**Mechanical characteristics holder LLH02DRA,**  
**dimension is in millimeters**  
**General tolerance +/-0.15 mm (standard NF T 58 -000 cat. 4, reduced class)**

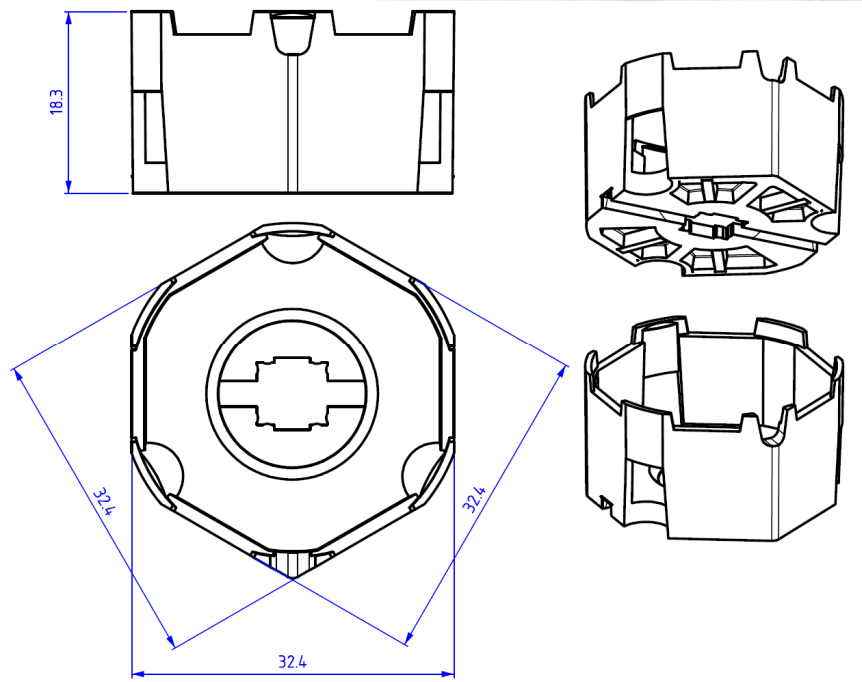

*Note: available with our adhesive ( acrylate or epoxy glu can also be used see your supplier).*

**Mechanical characteristics LLC17N**  
**without holder, dimensions are in millimeters**  
 General tolerance +/-0.15 mm (standard NF T 58-000 cat. 4, reduced class)

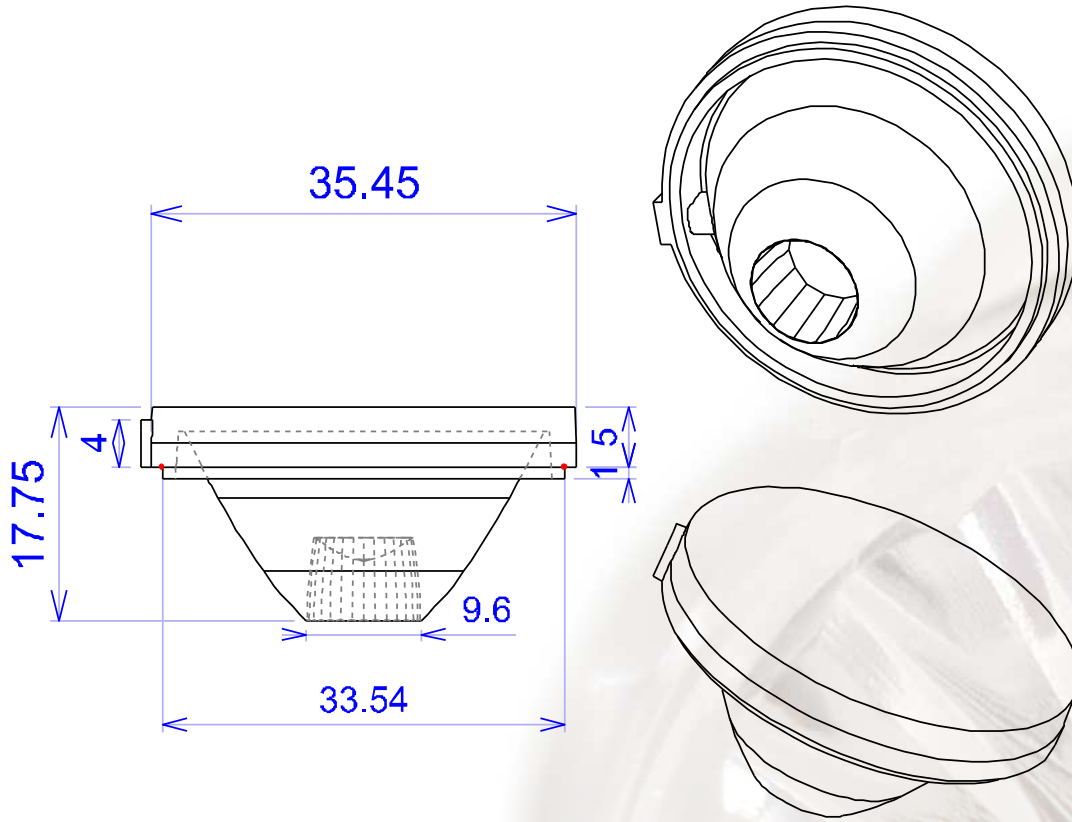

**Code form of LednLight products**

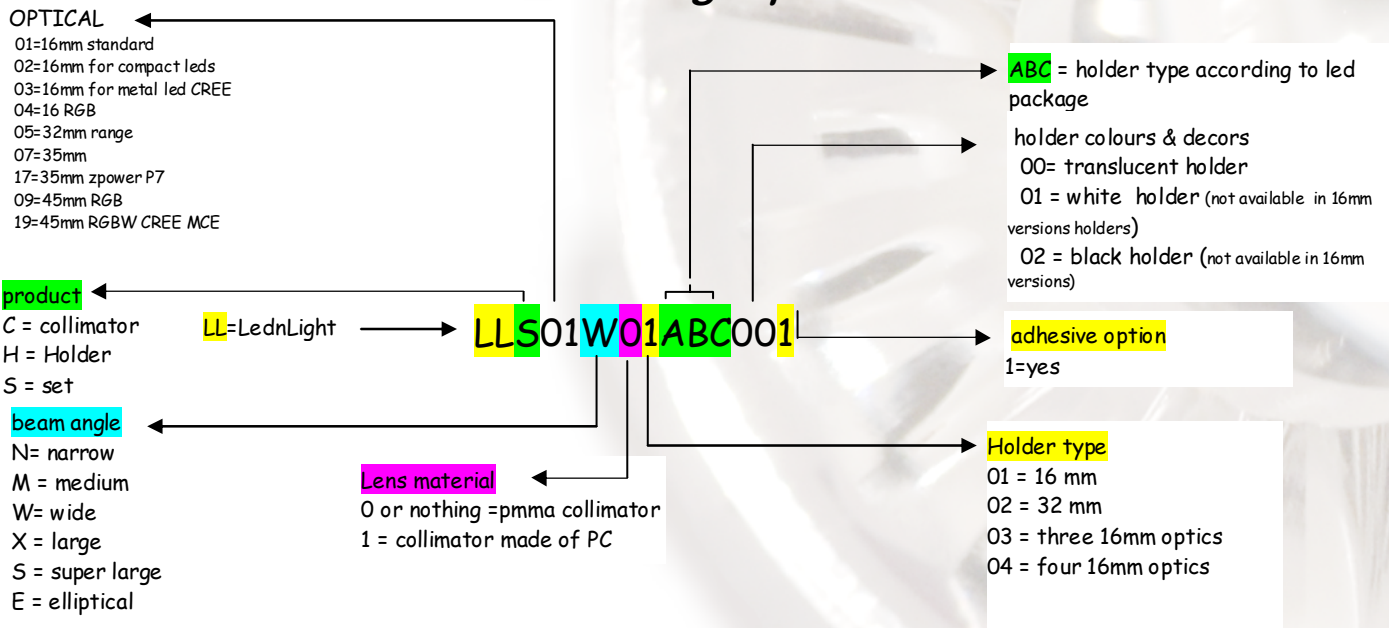

## Ordering code for LednLight series To be used with golden dragon

### 16mm

Collimateur Holder	Ø 16mm - narrow - étroit	Ø 16mm - medium - intermédiaire	Ø 16mm - large	Ø 16mm - extra-large	Ø 16mm - super -large	Ø 16mm - elliptic - elliptique
No holder	LLC01N	LLC01M	LLC01W	LLC01X	LLC01S	LLC01E
LLH01DRA00 Ø 16	LLS01N01DRA00	LLS01M01DRA00	LLS01W01DRA00	LLS01X01DRA00	LLS01S01DRA00	LLS01E01DRA00
LLH01DRA00 Ø 16 + adhesive	LLS01N01DRA001	LLS01M01DRA001	LLS01W01DRA001	LLS01X01DRA001	LLS01S01DRA001	LLS01E01DRA001
Three Ø 16 optics DRAGON HOLDER TRI LLH03DRA0(1) The (1) is for white	LLS01N03DRA01	LLS01M03DRA01	LLS01W03DRA01	LLS01X03DRA01	LLS01S03DRA01	LLS01E03DRA01
Four Ø 16 optics Holder QUADRI LLH04DRA01	LLS01N04DRA01	LLS01M04DRA01	LLS01W04DRA01	LLS01X04DRA01	LLS01S04DRA01	LLS01E04DRA01

**Note: single holders are translucent; tri and quadri are available in different colors and decors**

### 32&35 mm

Collimateur Holder	Ø 32mm - Narrow - étroit	Ø 32mm - Medium - intermédiaire	Ø 32mm - Wide	Ø 35mm - Narrow
No holder	LLC05N	LLC05M	LLC05W	LLC17N
LLH02DRA0x Ø 32	LLS05N02DRA00	LLS05M02DRA00	LLS05W02DRA00	-
LLH02DRA0x Ø 32 + adhesive	LLS05N02DRA001	LLS05M02DRA001	LLS05W02DRA001	-

## FAQ

**Q** – Of what material are Lednlight collimators made of ? Where are they manufactured ?

**A** – Lednlight collimators are made of a high purity grade PMMA, which guarantees a maximum luminous efficiency. Holders are made of PC. All our products are Made in France.

**Q** – What is Lednlight collimators luminous efficiency?

**A** – Luminous efficiency depends on the collimator itself and on the LED. It is between 85% and 93%.

**Q** – I would like to use a specific LED which is not mentioned in this datasheet. Is it possible?

**A** – LednLight collimators have a versatile design that can work with most LEDs references, allowing the user to choose the LED that best fits his needs. If your LED isn't mentioned in this datasheet, you can contact our engineering team which will give you more information.

**Q** – How can we position the LED compared to the collimator?

**A** – Mechanical drawings in pages 17~20 indicates the exact location of the focal point for each LednLight collimator. All you have to do is to put the LED chip at the focal point location.

**Q** – Can you provide CAD files of LednLight collimators?

**A** – The optical design is confidential, however CAD files of holder are available. You can upload them on our website. IES files and ray sets are also available on request.

**Q** – My project is very specific and custom. Lednlight collimator performances do not fit completely to my technical requirements.

**A** – Our engineers can design a custom version of the Lednlight collimators just for you, that will best fit your technical requirements, and at a very competitive price. Please do not hesitate to contact us to discuss your specifications.

**Q** – I would like to ask you a question which is not in the FAQ. How can I contact you?

**A** – Please visit our website : <http://www.lednlight.com> or contact us by phone : +33 (0) 4 74 76 12 66 or by email : [lednlight@gaggione.com](mailto:lednlight@gaggione.com)